

SHIBAURA Portable Fire-Fighting Pump

WATER COOLED 2 CYCLE Gasoline ENGINE with RADIATOR



FK500

SHIBAURA designed liquid-cooled engine prevent malfunction due to interfusion of waste water and dust into the engine chamber.

Easily warm up the engine with the idling, as the engine can be operated without discharging the water, and gives you the power of high combustion efficiency at any time.

The durability and long-lasting power offered by SHIBAURA's advanced engineering technology.

To satisfy all requirements for safe and reliable fire fighting activities

FK Series

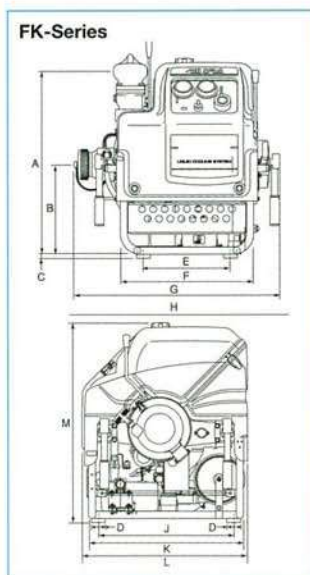

FK500

A	644
B	318
C	14
D	50
E	310
F	486
G	701
H	1040
J	483
K	552
L	590
M	766

FK500 Performance Curve

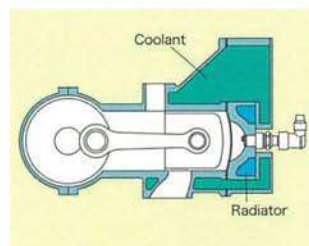
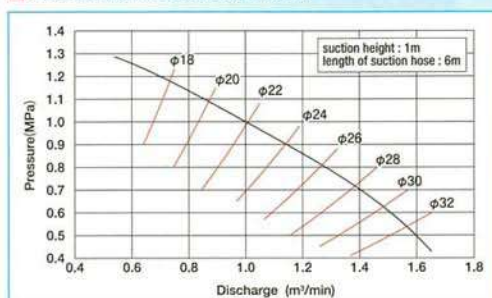

FULLY WATER COOLED RADIATOR

Fully Water Cooled Radiator gives longer life in the activities at dirty water area without overheating.



QUICK VALVE LEVER

Quick Valve Lever which allow you to operate valve faster and easier. Short stroke 45 degree lever device that is capable of shifting lever at once.



OILLESS VACUUM PUMP

Oilless Vacuum Pump uses high-strength carbon blades which does not need lubricating oil inside the pump. Harmless method to human and environment, as its doesn't discharge oily water on the ground.

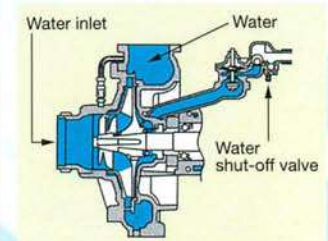

VACUUM PUMP SYSTEM

The maximum efficiency and lowest wear rate. Short suction procedure for your faster fire fighting activities and simple mechanism for your easy maintenance.